

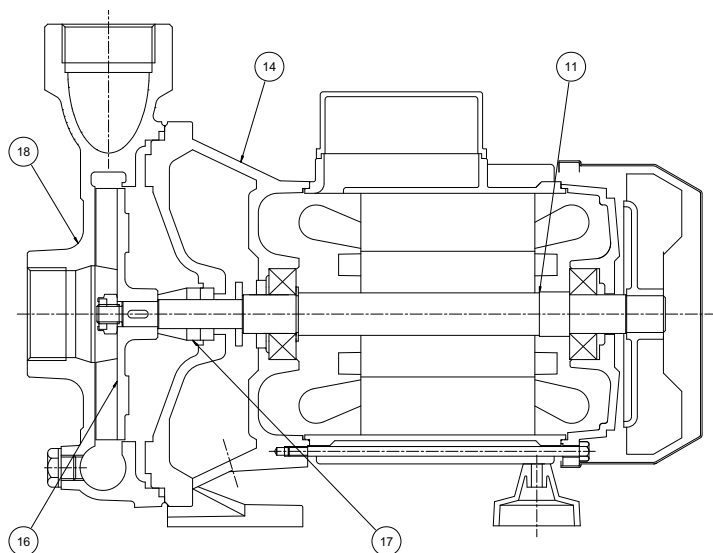

NOMENCLATURA PARTI DI RICAMBIO
SPARE PARTS LIST
NOMENCLATURE PIÈCES DE RECHANGE
NOMENCLATURA REPUESTOS



- 11** Albero con rotore – Pump shaft + rotor
Arbre + rotor – Eje rotor
- 14** Supporto mandata – Outlet bracket
Support envoyée – Soporte entrega
- 16** Girante – Impeller
Turbine – Impulsor
- 17** Tenuta meccanica – Mechanical seal
Garniture mécanique – Cierre mecánico
- 18** Corpo pompa – Pump body
Corp de pompe – Cuerpo bomba



ELETTROPOMPE CENTRIFUGHE A GIRANTE APERTA 1"1/2

Le elettropompe centrifughe monogiranti della serie STC sono state progettate per pompare liquidi puliti senza parti abrasive, senza corpi solidi in sospensione, non esplosivi o aggressivi per i materiali della pompa.

- Temperatura del liquido fino a 35 °C per uso domestico (CEI EN 60335-2-41) o 90 °C per altri usi e temperatura ambiente fino a 40 °C
- Portate fino a 30 m³/h
- Prevalenze fino a 22 m.

CARATTERISTICHE COSTRUTTIVE

Corpo pompa	Ghisa G20 con trattamento anticorrosione
Supporto motore	Ghisa G20 con trattamento anticorrosione
Girante	Ghisa G20 con trattamento anticorrosione (Tecnopolimero per STC 80-100)
Albero pompa	Acciaio inox AISI 304 (AISI 420 F per STC 80-100)
Tenuta meccanica	Carbone - Ceramica

MOTORE

I motori di comando sono del tipo asincrono a gabbia di scoiattolo chiusi, a ventilazione esterna.

- Motoprotettore incorporato e condensatore permanentemente inserito per i tipi monofasi
- La protezione del motore nella versione trifase è a cura del cliente e si raccomandano apparecchiature in accordo con le norme vigenti
- Isolamento classe F
- Servizio S1
- Grado di protezione IP 44
- Protezione morsettiera IP 54.

CENTRIFUGAL ELECTRIC PUMPS WITH OPEN IMPELLER 1"1/2

The close-coupled centrifugal electric pumps with one impeller series STC have been designed to pump clear liquids, without abrasives and suspended solids, non-explosive or aggressive for the pump's materials.

- Liquid temperature not higher than 35 °C for domestic use (CEI EN 60335-2-41) or 90 °C for other use, while the ambient temperature must not be higher than 40 °C
 Flow rate up to 30 m³/h
 Heads up to 22 m.

TECHNICAL FEATURES

Pump body	Cast iron G20 with anti-corrosive coating
Motor bracket	Cast iron G20 with anti-corrosive coating
Impeller	Cast iron G20 with anti-corrosive coating (Techno-polymer for STC 80-100)
Pump shaft	Stainless steel AISI 304 (AISI 420 F for STC 80-100)
Mechanical seal	Carbon - Ceramics

MOTOR

The control motors are asynchronous, squirrel cage-type, closed, with external ventilation.

- Incorporated motor protection and capacitor always on, for single-phase models
- The motor protection for three-phase models must be installed by the customer. Equipment compliant with current standards should be used
- Class of insulation F
- Service S1
- Degree of protection IP 44
- Terminal board protection IP 54.

ÉLECTROPOMPES CENTRIFUGES À ROUE OUVERTE 1"1/2

Les électropompes centrifuges à une roue de la série STC ont été conçues pour pomper des liquides propres sans parties abrasives, sans corps liquides en suspension, non explosifs ou agressifs pour les matériaux de la pompe.

- Température du liquide jusqu'à 35 °C pour utilisation domestique (CEI EN 60335-2-41) ou 90 °C pour d'autres utilisations et température ambiante jusqu'à 40 °C
- Plage d'utilisation jusqu'à 30 m³/h
- Hauteur manométrique jusqu'à 22 m.

CARACTERISTIQUES DE CONSTRUCTION

Corps de pompe	En fonte G20 avec traitement anti-corrosion
Lanterne	En fonte G20 avec traitement anti-corrosion
Turbine	En fonte G20 avec traitement anti-corrosion (Tecnopolymère pour STC 80-100)
Abre de pompe	Acier inox AISI 304 (AISI 420 F pour STC 80-100)
Garniture mécanique	Carbone - Céramique

MOTOR

Les moteurs sont asynchrones à cage d'écureuil fermés à ventilation extérieure monofásicos.

- Pour le modèles monophasé son avec protection thermique et condensateur connecté en permanence
- Pour les modèles triphasés, la protection est à la charge de l'utilisateur. A recommandé l'équipement conformément à la réglementation
- A Classe d'isolation F
- Service S 1
- Protection IP44
- Protection IP54 dans le terminal.

ELECTROBOMBAS CENTRÍFUGAS A IMPULSOR ABIERTO 1"1/2

Las electrobombas centrifugas con monoimpulsor della serie STC han sido proyectadas para bombear líquidos limpios sin partes abrasivas, sin cuerpos sólidos en suspensión, que no sean explosivos ni agresivos para los materiales de la bomba.

- Temperatura del líquido hasta 35 °C para uso doméstico (CEI EN 60335-2-41) o 90 °C para otros usos y temperatura ambiente hasta 40 °C
- Caudal hasta 30 m³/h
- Alturas hasta 22 m.

CARACTERÍSTICAS DE CONSTRUCCIÓN

Cuerpo de bomba	Fundición gris G20 con tratamiento contra-corrosión
Soporte	Fundición gris G20 con tratamiento contra-corrosión
Rodete	Fundición gris G20 con tratamiento contra-corrosión (De tecnopolímero para las STC 80÷100)
Eje de la bomba	Acero Inox AISI304 (AISI 420 F para las STC 80÷100)
Cierre mecánico	Cerámica - Grafito

MOTOR

Los motores de accionamiento son asíncrono de jaula de ardilla cerrados, ventilados externamente.

- Para los modelos monofásicos, protección térmica y condensador incorporado
- Para los modelos trifásicos se encarga el usuario de la protección del motor y se recomienda un equipo de acuerdo con las normas vigentes
- Aislamiento de Clase F
- Funcionamiento S1
- Protección IP44
- Protección IP54 para el terminal.

50 Hz - min⁻¹ ~ 2900

TIPO TYPE		Potenza nominale Nominal power		Potenza assorbita Input power [W]		Condensatore Capacitor 450 V max	Corrente assorbita Input current [A]			Portata - Capacity								
a	b	KW	HP	a	b	[μF]	1~ 230 V	3~ 230 V	3~ 400 V	Q [m ³ /h]	0	3	6	9	12	16,5	18	
										Q [l/1']	0	50	100	150	200	275	300	
										Prevalenza (m C.A.) - Total head (m W.C.)								
										H	m	17	16,3	14,5	13	11	6	
										Efficiency	%	0	32	52,5	60,5	59	31	
										P1	Kw	0,65	0,67	0,72	0,77	0,81	0,88	
										NPSH	m				1,6	1,8	4	
STC 80 M	STC 80 T	0,59	0,8	890	790	16	4,2	2,8	1,6	H	m	20	18,5	17	15,2	13	8,6	6
										Efficiency	%	0	32	52,5	66	71	61	51
										P1	Kw	0,93	0,97	11	15	1,1	1,16	1,18
										NPSH	m				1,6	1,8	4	
STC 100 M	STC 100 T	0,74	1	1130	1010	20	5,5	3,5	2	H	m	20	18,5	17	15,2	13	8,6	6
										Efficiency	%	0	32	52,5	66	71	61	51
										P1	Kw	0,93	0,97	11	15	1,1	1,16	1,18
										NPSH	m				1,6	1,8	4	

a) ~Monofase 230 V

b) ~Trifase 230/400 V

TIPO TYPE		Potenza nominale Nominal power		Potenza assorbita Input power [W]		Condensatore Capacitor 450 V max	Corrente assorbita Input current [A]			Portata - Capacity							
a	b	Kw	HP	a	b	[μF]	1~ 230 V	3~ 230 V	3~ 400 V	Q [m ³ /h]	0	6	12	18	24	27	
										Q [l/1']	0	100	200	300	400	450	
										Prevalenza (m C.A.) - Total head (m W.C.)							
										H	m	19	18,5	18	16,5	13,5	11
										Efficiency	%	0	37,5	58	67	65,5	61
										P1	Kw	1	1,19	1,38	1,57	1,76	1,85
										NPSH	m		2,6	1,4	2	4,2	6
STC 150 M	STC 150 T	1,1	1,5	2060	2020	31,5	9	6	3,5	H	m	20,5	21	20,5	19	16	14
										Efficiency	%	0	37,5	58	67	65,5	61
										P1	Kw	1,02	1,29	1,55	1,82	2,08	2,22
										NPSH	m		2,6	1,4	2	4,2	6
STC 200 M	STC 200 T	1,5	2	2370	2350	40	11,5	7,2	4,2	H	m	20,5	21	20,5	19	16	14
										Efficiency	%	0	37,5	58	67	65,5	61
										P1	Kw	1,02	1,29	1,55	1,82	2,08	2,22
										NPSH	m		2,6	1,4	2	4,2	6

a) ~Monofase 230 V

b) ~Trifase 230/400 V



60 Hz - min⁻¹ ~ 3400

TIPO TYPE		Potenza nominale Nominal power		Potenza assorbita Input power [W]		Condensatore Capacitor 450 V max	Corrente assorbita Input current [A]				Portata - Capacity								
a	b	kW	HP	a	b	[µF]	1~ 115 V	1~ 220 V	3~ 220 V	3~ 380 V	Prevalenza (m C.A.) - Total head (m W.C.)								
											Q [m ³ /h]	0	3	6	9	12	16,5	18	
											Q [l/1']	0	50	100	150	200	275	300	
STC 80 M	STC 80 T	0,59	0,8	870	760	18	8,5	4,5	3	1,6	H	m	18	17	15,8	13,9	12	8,1	6,1
											Efficiency	%	0	36,3	61	69,8	71,8	47,3	21,5
											P1	Kw	0,62	0,64	0,68	0,73	0,77	0,83	0,86
											NPSH	m				1,6	1,8	4	
STC 100 M	STC 100 T	0,74	1	1110	980	20	10,5	5,8	4,1	2,3	H	m	22	21	19,8	18,4	16,5	13	11,9
											Efficiency	%	0	20,9	37,6	50,1	59,3	58,4	51,5
											P1	Kw	0,88	0,92	0,96	1	1,04	1,1	1,12
											NPSH	m				1,6	1,8	4	5,8

a) ~Monofase 115/220 V

b) ~Trifase 220/380 V

TIPO TYPE		Potenza nominale Nominal power		Potenza assorbita Input power [W]		Condensatore Capacitor 450 V max	Corrente assorbita Input current [A]			Portata - Capacity							
a	b	Kw	HP	a	b	[µF]	1~ 220 V	3~ 220 V	3~ 380 V	Prevalenza (m C.A.) - Total head (m W.C.)							
										Q [m ³ /h]	0	6	12	18	24	27	
										Q [l/1']	0	100	200	300	400	450	
STC 150 M	STC 150 T	1,1	1,5	2040	1990	36	9,5	5,7	3,2	H	m	21	20,8	19,9	17,5	13,7	11,3
										Efficiency	%	0	40	62	66,6	65,4	53,3
										P1	Kw	0,95	1,13	1,31	1,49	1,67	1,76
										NPSH	m		2,6	1,4	2	4,2	6
STC 200 M	STC 200 T	1,5	2	2330	2320	40	12,5	7,0	4,6	H	m	24,0	23,8	23	22	19	17
										Efficiency	%	0	34,7	55,5	67,2	66,8	64,9
										P1	Kw	0,97	1,22	1,47	1,73	1,98	2,11
										NPSH	m		2,6	1,4	2	4,2	6

a) ~Monofase 220 V

b) ~Trifase 220/380 V

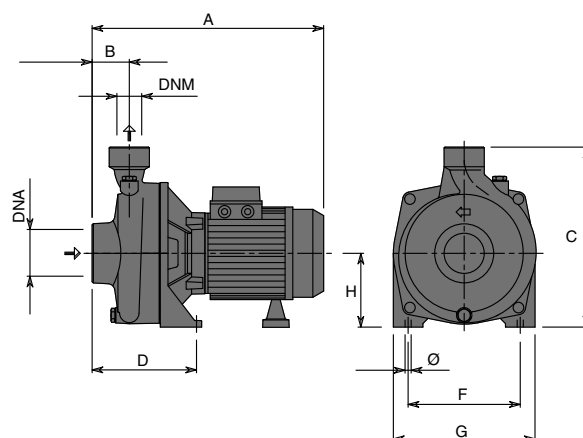

TIPO TYPE	DIMENSIONI [mm] DIMENSIONS [mm]										IMBALLO [mm] PACKING [mm]			PESO WEIGHT [kg]
	A	B	C	D	F	G	Ø	H	DNA	DNM	A	L	P	
STC 80	288	40	237	114	140	180	9	97	1" 1/2 G	1" 1/2 G	255	200	310	13
STC 100	288	40	237	114	140	180	9	97	1" 1/2 G	1" 1/2 G	255	200	310	14
STC 150	349	42	260	136	149	199	11	110	1" 1/2 G	1" 1/2 G	270	215	375	21
STC 200	349	42	260	136	149	199	11	110	1" 1/2 G	1" 1/2 G	270	215	375	23